

The Matson Evaluation of Social Skills with Youngsters (MESSY) and its Adaptation for Brazilian children and adolescents

Maycoln Leôni Martins Teodoro¹

Universidade do Vale do Rio dos Sinos, São Leopoldo, Brazil

Karl Christoph Käppler

Universität Zürich, Switzerland

Jussara de Lima Rodrigues

Patrícia Martins de Freitas

Vitor Geraldi Haase

Universidade Federal de Minas Gerais, Belo Horizonte, Brazil

Abstract

The present study reports the psychometrics properties of the adaptation of the Matson Evaluation of Social Skills with Youngsters (MESSY) to a Brazilian sample. The MESSY and the Family Identification Test (FIT) were completed by 382 children (215 females, 167 males) from urban middle-class areas and *favelas* (slums) of Belo Horizonte, Brazil. Age ranged from 7 to 15 years ($M=10.30$; $SD=2.24$). Results from factor analysis yielded a four-factor model with good internal consistency. One-Way Anova analyzes described boys as having higher scores on Factor 1 than girls (*Aggressiveness/Antisocial Behavior*). Children from urban middle-class areas performed better on factor 2 (*Social Skills/Assertiveness*) than those from *favelas*. Socio-cultural implications of the results are discussed.

Keywords: Children (Brazil); adolescents; social skills.

Escala Matson de Avaliação das Habilidades Sociais para Jovens (MESSY) e sua Adaptação para Crianças e Adolescentes Brasileiros

Resumo

O presente estudo descreve as propriedades psicométricas da adaptação da *Matson Evaluation of Social Skills with Youngsters* (MESSY) para uma amostra brasileira. A MESSY e o Teste de Identificação Familiar (FIT) foram completados por 382 crianças (215 meninas, 167 meninos) de áreas urbanas de classe média e favelas de Belo Horizonte, Brasil. A idade variou de 7 a 15 anos ($M=10.30$; $DP=2.24$). Resultados da análise fatorial produziram um modelo com quatro fatores com boa consistência interna. Análises de Variância *One-Way* mostraram que os meninos possuem escores superiores no fator 1 aos das meninas (*Agressividade/Comportamento Anti-social*). Crianças provenientes de áreas urbanas de classe média obtiveram uma melhor performance no fator 2 (*Habilidades Sociais/Assertividade*) do que aqueles das *favelas*. Implicações sócio-culturais dos resultados são discutidas.

Palavras-chave: Crianças (Brasil); adolescentes; habilidades sociais.

Social skills are a fundamental factor for the formation of relationships, for the quality of social interactions and even for the individual's mental health (Hay, 1994; Parker & Asher, 1987). Such skills can be defined as the complete pattern of behaviors showed by an individual during his/her interpersonal relations. In this sense, adaptive social behavior is a complex construct that involves intra-individual characteristics (micro-environment) as well as contextual factors (macro-environment) (Del Prette & Del Prette, 1999).

In the last few decades increased attention has been given to programs designed for children and adolescents with poor social skills. The development and evaluation of such programs must be based on appropriate measures that can identify the social deficits of children and adolescents and verify the effectiveness of these interventions. Normally these instruments are psychometric scales which are based on reports

from others (parents, teachers, etc.) about the child (e.g. "My son likes to play with other boys") or, rarely, on self-reports (e.g. I like to play with other boys.). Among the most widely used self-report scale to measure social skills is the "Matson Evaluation of Social Skills with Youngsters (MESSY)", developed by Matson, Rotatori and Helsel (1983).

The original version of the MESSY consist of 62 items divided in to six factors. Studies that evaluated the MESSY's psychometrics properties were conducted with samples from the United States (Kazdin, Matson, & Esveltd-Dawson, 1984; Matson, Esveltd-Dawson, & Kazdin, 1983; Matson, Heinze, Helsel, Kappermann, & Rotatori, 1986; Matson, Macklin, & Helsel, 1985), which, in general, demonstrated satisfactory results.

The MESSY has also been evaluated and adapted for others countries and different languages, e.g. Australia (Spence & Liddle, 1990), China (Chou, 1997 – this study was restricted to the first factor) and Spain (Méndez, Hidalgo, & Inglés, 2002). However, there is still no agreement about

¹ Address: Universidade do Vale do Rio dos Sinos, Centro da Saúde, Av. Unisinos, 950 - Bairro Cristo Rei - CEP 93.022-000 São Leopoldo - RS - Brazil. E-mail: mlmteodoro@compuserve.de

which factorial structure best explains the data because the results of former studies showed a different number of factors and different arrangements of items.

Thus, the objectives of the present study are to examine the psychometric properties of the MESSY for the first time in Latin America, i.e. in a Brazilian sample and to compare the results to foregoing studies with the MESSY in other socio-cultural contexts. Moreover, it will investigate the differences of social skills in children from urban middle-class areas and *favelas* (slums).

Materials and Methods

Sample

The sample included 382 children (215 females, 167 males) from four public schools in urban middle-class areas of Belo Horizonte, the third largest city in Brazil (3.5 million). 234 children were from schools A and B, located in urban middle-class areas (96 males and 138 females), and 148 children were from schools B and C, sited in so-called *favelas* (71 males and 77 females). Age ranged from 7 to 15 years ($M=10.30$; $SD=2.24$). The demographic composition of the sample is shown in Table 1.

Instruments

The *Matson Evaluation of Social Skills with Youngsters* (MESSY) is a self-report measure developed by Matson, Rotatori and Helsel (1983). The scale consists of 62 items, which are rated by the child or adolescent according to a five-point Likert scale. The items are related to 6 factors/dimensions originally named 'Appropriate Social Skill', 'Inappropriate Assertiveness', 'Impulsive/Recalcitrant', 'Overconfident', 'Jealousy/Withdrawal' and 'Miscellaneous Items' (rest of the items difficult to classify).

The MESSY was translated into Portuguese by three native speakers. Subsequently this version was modified by two other Brazilians in order to achieve a better understanding by persons with lower levels of formal education, while at the same time, retaining the original meaning of the items.

The *Family Identification Test* (FIT; Remschmidt & Mattejat, 1999) is an instrument that was developed in Germany for the assessment of self-congruence ('I am how I would like to be') and real identification (e.g. 'I am like my mother/father'). It consists of 12 attributes (self-confident, independent,

anxious, moody, nervous, content, calm, lively, communicative, understanding, respectful, friendly) derived from the following personality concepts: 'Social Activity', 'Assertiveness', 'Social Resonance' and 'Emotional Stability/Lability'. The child first has to describe him/herself (real self), how he/she would like to be (ideal self), and subsequently the family members or closer social context characterized as 'significant others' (his/her parents, a best friend of him/her and his/her teacher). Each item has to be evaluated in reference to the person described along to a Likert scale ranging from one (not at all corresponding) to five (corresponding perfectly). The correlations between the real and ideal self defines the self-congruence. The identification patterns are obtained indirectly through the correlation between the description of another person and the real self (real identification with this person). Previous studies with the FIT had showed its capacity to discriminate clinical from non-clinical populations (Käppler, 1998) as well as its successful adaptation to a Brazilian sample (Teodoro, 2000).

Procedure

After contacting the schools the authors explained the background of the study to the teachers. Subsequently the students were informed about the project. They received a confirmation letter, which had to be signed by their parents.

The children, who were authorized to participate in this study, completed the self-report version of the Matson Evaluation of Social Skills with Youngsters (MESSY) and the Family System Test (FIT) individually, with the presence of one of the authors who was ready to answer questions in case of any doubt.

Results

In the current study, as the first step of data analysis, an exploratory factorial analysis was conducted to determinate the most appropriate dimensional structure for the given data set. Next, the model found was submitted to a confirmatory factorial analysis based on its covariance structure as well as to an analysis of internal consistence. Thirdly, the MESSY's results were compared with personality concepts and with identification patterns obtained using the FIT. Finally, the MESSY factors were analyzed according to differences in gender, age and socio-economic conditions.

Table 1
Demographic Composition of the Sample

	Age (years)									Total
	7	8	9	10	11	12	13	14	15	
Urban Area	26 (11.1%)	29 (12.4%)	35 (15%)	36 (15.4%)	18 (7.7%)	20 (8.5%)	30 (12.8%)	21 (9%)	19 (8.1%)	234 (61.3%)
<i>Favelas</i>	13 (8.8%)	18 (12.2%)	39 (26.4%)	35 (23.6%)	25 (16.9%)	9 (6.1%)	7 (4.7%)	2 (1.3%)	0 (0%)	148 (38.7%)
Total	39 (10.2%)	47 (12.3%)	74 (19.4%)	71 (18.6%)	43 (11.3%)	29 (7.6%)	37 (9.6%)	23 (6%)	19 (5%)	382 (100%)

Exploratory Factor Analysis

Exploratory factor analysis was performed using the principal components method (PCA) and Oblimin rotation with the Statistical Program for Social Sciences (SPSS 8®). As the most widely used criterion to determine the number of factors the scree plot method was chosen (Cattell, 1966).

The items and their loadings, and the variance explained by each factor are shown in Table 2. The result of the Kaiser-Meyer-Olkin measure of sampling adequacy was .827, indicating appropriateness of the factor analysis.

The initial results suggested a four factor solution that explained 29.7% of the total variance. A set of six items showed saturation lower than .30 (Item 08 and 62 from the first factor, Item 01 and 58 from the second factor and items 10 and 54 from the fourth factor). Nevertheless these items were maintained in the model in order to retain the possibility for international comparison.

The first factor explained 13.6% of the total variance and was named 'Aggressiveness/Antisocial Behavior'. The second factor, 'Social Skills/Assertiveness', explained 9.4% of the variance. The third factor, 'Conceit/Haughtiness', explained 3.5% of the variance and the last factor, called 'Loneliness/Social Anxiety' explained another 3.2% of the variance.

Correlations Among the MESSY Factors

The correlations among the four factors are shown in Table 3. There are three significant correlations at the level of $p < .01$: between factors 1 and 3 ($r = .54$), 1 and 4 ($r = .36$;) and between factors 3 and 4 ($r = .33$; $p < .01$). Another significant difference at the level of $p < .05$ was found between factors 2 and 4 ($r = .12$; $p < .05$). Only two of six possible associations were not correlated significantly: factor 2 with factor 1 and with factor 3.

Table 2
Items of the MESSY and their Distribution to Factors after Oblimin Rotation

Items	Factors			
	1	2	3	4
Factor 1: <i>Aggressiveness/Antisocial Behavior</i>				
41. I speak too loudly.	.656		-.221	
35. I am stubborn.	.618		-.204	.215
30. I make fun of others.	.607			
06. I speak (interrupt) when someone else is speaking.	.593			
53. I get into fights a lot.	.586			
22. I pick on people to make them angry.	.570	-.203		
07. I take or use things that are not mine without permission.	.558			
11. I slap or hit when I am angry.	.522			
39. I make sounds that bother others (burping, sniffing).	.508			
21. I lie to get something I want.	.502			
17. I pick out other children's faults/mistakes.	.491			
02. I threaten people or act like a bully.	.478			
05. I gripe or complain often.	.445			
14. I give others children dirty looks.	.444			
38. I think that people are picking on me when they are not.	.435		.238	
04. I am bossy (tell people what to do instead of asking).	.428			
19. I break promises.	.413			
29. I hurt others' feelings on purpose (I try to make people sad).	.398			
61. I hurt others when teasing them.	.378			
03. I become angry easy.	.316			
62. I want to get even with someone who hurts me.	.289			.270
08. I brag about myself.	.270		.235	
Factor 2: <i>Social Skills/Assertiveness</i>				
12. I help a friend who is hurt.		.639		
13. I cheer up a friend who is hurt.		.610		
44. I feel good if I help someone.		.589		
43. I ask if I can be of help.		.576		
56. I ask others how they are, what they have been doing, etc.		.558		
55. I do nice things for people who are nice to me.		.554		
31. I stick up for my friends.		.548		
32. I look at people when they are speaking.	-.219	.508		
24. I say 'thank you' and I am happy when someone does something for me.		.481		
59. I laugh at others people's jokes and funny stories.		.467		
34. I share what I have with the others.		.466		

Table 2.

Items of the MESSY and their Distribution to Factors after Oblimin Rotation (continuation)

Items	Factors			
	1	2	3	4
28. I know how to make friends.		.458		-.221
16. I feel happy when someone else does well.		.453		
46. I ask questions when talking with others.		.450		
50. I feel sorry when I hurt someone.		.444	-.225	
20. I tell people they are look.		.437		
23. I walk up to people and start a conversation.	.230	.434		
47. I see my friends often.		.422		
42. I call people by their names.	-.229	.402		
40. I take care of other's property as if it were my own.		.388		
37. I show my feelings.		.387		
27. I keep secrets well.		.361		
52. I join in games with others children.		.333	.243	
09. I look at people when I talk with them.		.322		
58. I explain things more than I need to.		.262		
01. I make other people laugh.		.257		
Factor 3: <i>Conceit/Haughtiness</i>				
45. I try to be better to every one.			.639	
60. I think that winning is everything.			.634	
33. I think I know it all.			.601	
18. I always want to be the first.			.578	
51. I like to be the leader.			.536	
15. I feel angry or jealous when someone else does well.			.505	
36. I act like I am better than other people.	.348		.454	
57. I stay with the others too long (wear out ma welcome).			.336	.261
Factor 4: <i>Loneliness/Social Anxiety</i>				
49. I feel lonely.				.640
48. I play alone.			.206	.604
25. I like to be alone.				.492
26. I am afraid to speak to people.	.258			.390
10. I have many friends.		.276		-.297
54. I am jealous of the others people.	.251		.233	.279

Table 3

Correlations among the MESSY Factors in the Brazilian Sample

MESSY Factors	Aggressiveness/ Antisocial Behavior	Social Skills/ Assertiveness	Conceit/ Haughtiness	Loneliness/ Social Anxiety
Aggressiveness/Antisocial Behavior	-			
Social Skills/Assertiveness	-.091	-		
Conceit/Haughtiness	.541**	.043	-	
Loneliness/Social Anxiety	.357**	.124*	.333**	-

Note. * $p < .05$; ** $p < .01$ **Confirmatory Factor Analysis**

In order to prove the four factors structure, a confirmatory factor analysis (CFA) was carried out with the Lisrel 5.51@ program (Jöreskog & Sörbom, 2001). The CFA model has four latent variables, which are the four factors found in the exploratory analysis. In order to have a proper measurement model with at least two observed variable, each factor was divided in two parallel tests according to their correlation matrices (called sub01_A, sub01_B, sub02_A, sub02_B, sub03_A, sub03_B, sub04_A and sub04_B respectively). Additionally, their total sums entered the model. The correlations between the parallel tests are .81 (for the first

factor's subtests), .75 (for the second factor's subtests), .62 (for the third factor's subtests) and finally .38 (for the fourth factor's subtests). The factors were allowed to covary freely in the model, and each item received two paths, one from its respective latent variable and another from the 'error'-term. All the paths from the latent variable were fixed in 'one' and the paths from the error were let free. The latent variables are displayed in ellipses and the observed variables in rectangles. Goodness of fit was evaluated with a number of indicators including the Root-Mean-Square Error of Approximation (RMSEA), Goodness-of-Fit-Index (GFI) and the Adjusted-Goodness-of-Fit-Index (AGFI) (Bentler & Bonett, 1980;

Byrne, 1989; Carmines & McIver, 1981). The model and its standardized values are shown in Figure 1.

Before the final evaluation of the Model's fit, it is important to underscore to some results shown in Figure 1. First, the paths from the latent to the manifest variables showed high scores, meaning that the latent variable could explain a high percentage of variance related to manifest scores. The error measures, however, showed small contributions to manifest variables.

In sum, the results confirmed the hypothesis that the four-factor model provides a good fit with the data set. The chi-square (X^2) was 48.03 with 18 degrees of freedom. Goodness of fit was highly confirmed (RMSEA= .065; GFI= .97 and AGFI= .94).

Reliability

The reliability of the scale was calculated by the internal consistency coefficients (Cronbach's alpha). The total alpha was .85. The first factor (*Aggressiveness/Antisocial Behavior*) represented an alpha of .87, factor 2, *Social Skills/Assertiveness*, showing an alpha of .84. The third factor, *Conceit/Haughtiness*, is characterized by an alpha of .74 and the last factor, *Loneliness/Social Anxiety*, showed an alpha of .47.

Correlation with the Family Identification Test (FIT)

Table 4 displays the Pearson correlations between the four factors of the MESSY and the results obtained by the Family Identification Test (FIT). There are many significant associations between the two instruments, especially with factor 1 of the MESSY (*Aggressiveness/Antisocial behavior*), which is (negatively) correlated with almost all indicators of the FIT on the self-concept, identification and personality dimension level. There are also positive correlations between factor 2 (*Social Assertiveness*) and the FIT's social activity and social resonance dimension ($p < .001$) as well as with real identifications towards mother and best friend ($p < .05$). Factor

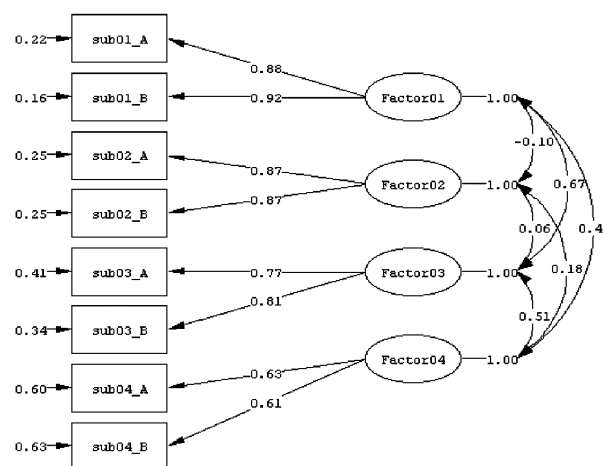

Chi-Square=48.03, df=18, P-value=0.00015

Figure 1. Confirmatory Factor Analysis of the Four-Factor MESSY and Standardized Results

3 (*Conceit/Haughtiness*) is also connected (negatively) to identification patterns towards significant others and self-congruence, as well as (positively) to the emotional lability dimension, whereas factor 4 (*Loneliness/Social Anxiety*) does not show any link to FIT variables.

In summary, the total score of the MESSY shows some associations with the FIT's dimensions of social activity and emotional lability as well as with self-congruence and real identification towards mother and best friend.

Gender, Age and different school environments

Analyses of Variance (Anova) with subsequent single t-Tests were conducted in order to determine differences regarding gender, age and school context. The level of significance was defined as $p < .01$. Table 5 offers the means and standard deviations for the four factors of the MESSY differentiated by gender and school environment.

Concerning gender differences, there was only one single statistically significant result found, indicating lower score for

Table 4

Correlations between the MESSY Factors and the Family Identification Test (FIT)

Family Identification Test (FIT)	MESSY				MESSY Total Score
	Aggressiveness/ Antisocial Behavior	Social Skills/ Assertiveness	Conceit/ Haughtiness	Loneliness/ Social Anxiety	
Social activity	.126*	.226***	.052	-.074	.213**
Assertiveness	.039	.033	.063	-.001	.067
Social resonance	-.279***	.314***	-.050	.056	.039
Emotional Lability	.268***	.016	.173**	.042	.220***
Self-Congruence	-.252***	.090	-.142*	-.015	-.125*
Real Identification with the mother	-.257***	.124*	-.150*	-.072	-.124*
Real Identification with the father	-.223***	.068	-.126*	-.025	-.120
Real Identification with best friend	-.247***	.144*	-.225***	-.068	-.125*
Real Identification with teacher	-.246***	.112	-.138*	-.046	-.111

Note. * $p < .05$; ** $p < .01$; *** $p < .001$.

Table 5
Means and Standard Deviations for the four Factors of the MESSY Differentiated by Gender and School Context

Factor 1:	Urban middle-class areas	Favelas	Total
<i>Aggressiveness/Antisocial Behavior</i>			
Male	20.54 (6.76)	20.13 (8.19)	20.37 (7.38) ^a
Female	18.46 (5.58)	17.39 (5.01)	18.07 (5.40) ^a
Total	19.31 (6.17)	18.7 (6.84)	19.08 (6.43)
<i>Factor 2: Social Skills/Assertiveness</i>			
Male	50.01 (6.83)	48.18 (9.50)	49.28 (8.10)
Female	52.55 (6.74)	48.84 (8.20)	51.22 (7.50)
Total	51.54 (6.87) ^b	48.53 (8.82) ^b	50.37 (7.81)
<i>Factor 3: Conceit/Haughtiness</i>			
Male	8.3 (3.47)	8.83 (3.64)	8.53 (3.54)
Female	7.59 (2.76)	7.91 (2.94)	7.71 (2.83)
Total	7.88 (3.09)	8.35 (3.32)	8.07 (3.18)
<i>Factor 4: Loneliness/Social Anxiety</i>			
Male	9.07 (2.05)	8.13 (2.18)	8.67 (2.16)
Female	8.93 (1.94)	8.54 (2.30)	8.8 (2.08)
Total	8.99 (1.99)	8.34 (2.25)	8.74 (2.11)

Note. ^a Male scored significantly higher on factor 1 than females ($p < .001$). ^b Children from urban middle-class areas scored significantly higher on factor 2 than children from favelas ($p < .001$).

girls on factor 1, *Aggressiveness/Antisocial Behavior*, ($T = -2.846$; $p < .001$) in comparison to boys. In reference to the other three factors there no statistically relevant differences were found.

Similarly, Anova with age groups did not show any significant results in relation to MESSY dimensions. The results referring to school context did not show any difference between schools A and B and between schools C and D. Thus, it was decided to group schools A and B (children living in urban middle-class areas) and schools B and D (children living in favelas) together. The analysis of these two groups showed a significant difference on factor 2 - *Social Skills/Assertiveness* - ($T = 4.203$; $p < .001$), in which the children from middle-class neighborhoods scored higher than the children living in favelas. Moreover, no other significant difference was found relating to factors 1 (*Aggressiveness/Antisocial Behavior*), 3 (*Conceit/Haughtiness*) and 4 (*Loneliness/Social Anxiety*).

Univariate Analyses with these variables (sex, age and different schools) were also performed. The results showed no significant interactions among these variables.

Discussion

The Matson Evaluation of Social Skills with Youngsters (MESSY) has previously been applied in various countries and languages. To give an overview, Table 6 was adapted from Méndez, Hidalgo & Inglés (2002) and completed with the results of the present study. It provides a synopsis of the results obtained with the MESSY in different (socio-cultural) contexts.

The first two studies were conducted in the U.S. and Australia. In their original study Matson, Rotatori and Helsel (1983) used the principal component method with Varimax rotation and the criterion of Kaiser to determine the number of factors to be extracted. The result was a model with five factors and a set of miscellaneous items, described in Table 6.

In their paper they did not mention the percentage of variance explained. Spence and Liddle (1990) found a model with seven factors, which explained 77% of the variance. However, due to the similarities between the two first factors of the Australian and North American model, the authors decided to accept the original model with five factors. In the study the authors used also the principal component method with Varimax rotation and the criterion of Kaiser to determine the number of factors.

The most recent studies were an adaptation of the MESSY to the Latin cultural context with the translation into Spanish (Méndez, Hidalgo, & Inglés, 2002) and into Portuguese (in the current study). The findings of both studies presented similar factor solutions, which are characterized by four factors and account for, approximately, the same amount of variance explained (33.28% and 29.7% respectively). In these cases, the method used to define the appropriate number of factors was the scree plot in contrast to the former studies.

The global analysis of factorial structures given in Table 6 reveals that all studies found approximately the same first two factors, even when they were named differently. Furthermore, there is a similarity among factor 3 as found in the studies of Spence and Liddle (1990), Méndez, Hidalgo and Inglés (2002) and the current study. However, the biggest factorial consistency was found in the last two studies in the Latin context. Both arrived at basically the same factorial structure, with only small changes in some items. As it was already mentioned above, in these studies the scree plot method was used as the criterion for the selection of the number of factors in contrast to the other studies, where the Kaiser criterion was applied, which selects factors with an Eigenvalue larger than 1. This means, if factors with low Eigenvalues present a small variation from one study to another, they could disappear. This was the case, for instance, in the original study of Matson, Rotatori and Helsel (1983). While the first two factors, stable in all studies, presented high Eigenvalues (10.59 and 4.23), factors 3, 4 and

Table 6
Comparison of MESSY Factor Structure among Different Studies

Authors	Factor structure	Item numbers
Matson, Rotatori & Helsel (1983) from the U.S.	Factor 1: Appropriate Social Skills	9, 10, 12, 13, 16, 20, 23, 24, 28, 31, 32, 34, 37, 40, 42, 43, 44, 46, 50, 52, 55, 56, 59
	Factor 2: Inappropriate Assertiveness	2, 7, 11, 14, 17, 19, 21, 22, 29, 30, 39, 41, 53, 60, 61, 62
	Factor 3: Impulsive/Recalcitrant.	3, 4, 5, 6, 35
	Factor 4: Overconfident	8, 33, 36, 57, 58
	Factor 5: Jealousy/Withdrawal	15, 38, 49, 54
	Miscellaneous Items	1, 18, 25, 26, 27, 45, 47, 48, 51
Spence & Liddle (1990) from Australia	Factor 1: Appropriate Social Skills	9, 12, 13, 16, 20, 23, 24, 27, 28, 31, 32, 34, 37, 40, 42, 43, 44, 46, 47, 50, 52, 55, 56, 59
	Factor 2: Aggressive/Antisocial	2, 3, 4, 5, 6, 7, 8, 11, 14, 15, 17, 18, 21, 29, 30, 35, 53, 54
	Factor 3: Overconfident/Competitive	18, 33, 36, 45, 51, 60
	Factor 4: Loneliness/Hostility	22, 38, 41, 48, 49, 53
	Factor 5: Friendship	10, 28, 52
	Factor 6: Miscellaneous	23, 54, 61
	Factor 7: Cruelty/Social Anxiety	19, 26, 29, 30
Méndez, Hidalgo, & Inglés (2002) from Spain	Items deleted from the scale	1, 25, 39, 57, 58, 62
	Factor 1: Aggressive/Antisocial Behavior	2, 3, 4, 5, 6, 7, 8, 11, 14, 15, 17, 19, 21, 22, 29, 30, 35, 36, 38, 39, 41, 53, 54, 58, 60, 61, 62
	Factor 2: Social Skills/Assertiveness	1, 9, 10, 12, 13, 16, 20, 23, 24, 27, 28, 31, 32, 34, 37, 40, 42, 43, 44, 46, 47, 50, 52, 55, 56, 57, 58, 59
Teodoro et al. (current study) from Brazil	Factor 3: Conceit/Haughtiness	18, 33, 36, 45, 51
	Factor 4: Loneliness/Social Anxiety	10, 25, 26, 28, 48, 49
	Factor 1: Aggressive/Antisocial Behavior	2, 3, 4, 5, 6, 7, 8, 11, 14, 17, 19, 21, 22, 29, 30, 35, 38, 39, 41, 53, 61, 62
	Factor 2: Social Skills/Assertiveness	1, 9, 12, 13, 16, 20, 23, 24, 27, 28, 31, 32, 34, 37, 40, 42, 43, 44, 46, 47, 50, 52, 55, 56, 58, 59
	Factor 3: Conceit/Haughtiness	15, 18, 33, 36, 45, 51, 57, 60
	Factor 4: Loneliness/Social Anxiety	10, 25, 26, 48, 49, 54

5, which are present only in the first study, showed Eigenvalues of 1.91, 1.18 and 1.09 respectively. This could be – as an alternative to the hypothesis of cultural differences - another explanation for the variation of factor numbers in these studies. In fact, the method of Kaiser has already been criticized by many authors (e.g. Reise, Waller, & Comrey, 2000; Zwick & Velicer, 1986) for overestimating or underestimating the number of factors.

Another difference in the type of analysis used refers to the method of rotation. All the studies, except for the present one, used varimax, which rotation Varimax that does not allow the factors to be correlated to each other. Due to the lack of theoretical evidences for the non-inexistence of correlation among factors, the use of Oblimin was chosen for this study. It is important to point out that this method does not exclude the possibility of an orthogonal solution, if it really exists. However, the findings showed in fact many significant correlations between the factors.

The model with four factors was verified by confirmatory factorial analysis carry out in Lisrel. The general measures of fit showed that it is an appropriate model to interpret the results of the Brazilian study sample. Moreover, analyses with Cronbach's Alpha showed satisfactory reliability indicators for the Brazilian version of the MESSY.

Correlations among the scores of MESSY factors and the Family Identification Test showed an inverse relation between real identification with the parents, best friend and teacher and aggressive behavior. These results emphasize the importance of those people as model of learning to the children, to offer them the opportunity to learn social skills appropriately. Moreover there is a positive correlation between the factor 2 (*Social Skills/Assertiveness*) and social resonance, which indicates that both scales are measuring the same construct.

Results about gender difference showed that males presented higher scores in aggressiveness and antisocial behavior than females. This result is supported by the study of

Méndez, Hidalgo and Inglés (2002). Only the original study (Matson, Rotatori, & Helsel, 1983) did not find any gender differences. Related to age the results showed an inconsistent pattern among the studies with the MESSY. While the present study did not find any significant differences, the others found some covariations with age.

The present study also investigated different groups of children living in diverse social contexts (urban middle-class and very poor areas). The results revealed that children from middle-class neighborhoods scored higher on appropriate social behavior than children from *favelas*. The low scores in social behaviors indicate deficits in these children's behavior repertoire, which are probably due to psychosocial stress factors associated with poverty. The socio-economic conditions in which these children grow up generate a risk pattern for unstable family relationships, diseases, unemployment and, as a consequence, the children's circulation among different primary caretakers (Schmiedt Streck, 2000). Such constantly changing and complex living conditions can easily be imagined as offering fewer opportunities for adequate modeling processes in relationships and social interactions, what also contributes to a deficit in the acquisition of behaviors considered socially more adequate in these children (Eisenberg, Fabes, Schaller, Carlo, & Miller, 1991).

As a final conclusion, the current study presented a successful adaptation of the Matson Evaluation of Social Skills with Youngsters (MESSY) to the Brazilian context. The results on psychometric properties are convincing and confirm the Spanish results from Méndez, Hidalgo and Inglés (2002). Subsequent studies are necessary to further evaluate the instrument itself (e.g. in terms of its temporal stability in longitudinal designed studies) as well as its application in different cultural and also clinical contexts.

References

- Bentler, P. M., & Bonett, D. G. (1980). Significance tests and goodness-of-fit in the analysis of covariance structures. *Psychological Bulletin*, 88, 588-606.
- Byrne, B. M. (1989). *A primer of Lisrel. Basic applications and programming for confirmatory factor analytic models*. New York, USA: Springer-Verlag.
- Carmines, E. G., & McIver, S. P. (1981). Analyzing models with unobserved variables: Analysis of covariance structures. In G. W. Bohrnstedt & E. F. Borgatta (Eds.), *Social measurement: Current issues* (pp. 65-115). Beverly Hills, USA: Sage.
- Cattell, R. B. (1966). The scree test for the number of factors. *Multivariate Behavioral Research*, 1, 245-276.
- Chou, K. L. (1997). The Matson Evaluation of Social Skills with Youngsters: Reliability and validity of a Chinese translation. *Personality and Individual Differences*, 22, 123-125.
- Del Prette, Z., & Del Prette, A. (1999). *Psicologia das habilidades sociais. Terapia e educação*. São Paulo, Brasil: Ed. Vozes.
- Eisenberg, N., Fabes, R. A., Schaller, M., Carlo, G., & Miller, P. A. (1991). The relations of parental characteristic and practices to children's vicarious emotional responding. *Child Development*, 62, 1393-1408.
- Hay, D. F. (1994). Prosocial development. *Journal of Child Psychology and Psychiatry*, 35, 29-71.
- Jöreskog, K. G., & Sörbom, D. (2001). LISREL 8.51 [Computer software]. Chicago, USA: Scientific Software International Inc.
- Käppler, K. C. (1998). Padrões de identificação em famílias: Um estudo comparativo entre crianças com e sem problemas psicológicos. *Cadernos de Psicologia*, 8, 241-252.
- Kazdin, A. E., Matson, J. L., & Esveldt-Dawson, K. (1984). The relationships of role-play assessment of children's social skills to multiple measures of social competence. *Behavior Research and Therapy*, 22, 129-140.
- Matson, J. L., Esveldt-Dawson, K., & Kazdin, A. (1983). Validation of methods for assessing social skills in children. *Journal of Clinical Child Psychology*, 12, 174-180.
- Matson, J. L., Heinze, A., Helsel, W. J., Kappermann, G., & Rotatori, A. F. (1986). Assessing social behaviors in the visually handicapped: The Matson Evaluation of Social Skills with Youngsters (MESSY). *Journal of Clinical Child Psychology*, 15, 78-87.
- Matson, J. L., Macklin, G. F., & Helsel, W. J. (1985). Psychometric properties of the Matson Evaluation of Social Skills with Youngsters (MESSY) with emotional problems and self-concept in deaf children. *Journal of Behavior Therapy and Experimental Psychiatry*, 16, 117-123.
- Matson, J. L., Rotatori, A. F., & Helsel, W. J. (1983). Development of a rating scale to measure social skills in children: The Matson Evaluation of Social Skills with Youngsters (MESSY). *Behavior Research and Therapy*, 21(4), 335-340.
- Méndez, F. X., Hidalgo, M. D., & Inglés, C. J. (2002). The Matson Evaluation of Social Skills with Youngsters. Psychometric properties of the Spanish translation in the adolescent population. *European Journal of Psychological Assessment*, 18, 30-42.
- Parker, J. G., & Asher, S. R. (1987). Peer relations and the later personal adjustment: Are low-accepted children at risk? *Psychological Bulletin*, 102, 357-389.
- Reise, S. P., Waller, N. G., & Comrey, A. L. (2000). Factor analysis and scale revision. *Psychological Assessment*, 12, 287-297.
- Remschmidt, H., & Mattejat, F. (1999). *Der Familien-Identifikations-Test (FIT). Manual* [The Family Identification Test. Manual]. Göttingen, Deutschland: Hogrefe.
- Schmiedt Streck, V. (2000). *Multiproblem-Familien im Kontext der Armut: Erfahrungen aus der Familienberatung in Lateinamerika* [Multi-problem families in the context of poverty: Experiences from family counseling in Latin America]. *System Familie*, 13, 14-21.
- Spence, S.H. & Liddle, B. (1990). Self-report measures of social competence for children: An evaluation of social skills for youngsters and the List of Social Situation Problems. *Behavioral Assessment*, 12, 317-336.
- Teodoro, M. L. M. (2000). *Habilidades sociais e processos de identificação em crianças e adolescentes*. Dissertação de Mestrado não publicada, Universidade Federal de Minas Gerais, Belo Horizonte, Brasil.
- Zwick, W. R., & Velicer, W. F. (1986). Comparison of five rules for determining the number of components to retain. *Psychological Bulletin*, 99, 432-442.

Received 02/01/2005

Accepted 02/04/2005

Maycoln Leôni Martins Teodoro. Psychologist, M.A. in social psychology, Ph.D. in developmental and family psychology, associate professor, Universidade do Vale do Rio dos Sinos.

Karl Christoph Käppler, Ph.D. Head of Psychology, Department of Child and Adolescent Psychiatry, University of Zurich, Switzerland

Jussara Rodrigues Lima. Psychologist, M.A. student in psychology, Universidade Federal de Minas Gerais.

Patrícia Martins de Freitas. Neuropsychologist of Associação Mineira de Reabilitação, M.A. in psychology, Ph.D. student in Pediatrics, Universidade Federal de Minas Gerais.

Vitor Geraldi Haase. Neurologist, M.A. in linguistics, Ph.D. in medical psychology, associate professor, Departamento de Psicologia, Universidade Federal de Minas Gerais.